

DATA SHEET

2322 592 to 2322 595

Varistors

Product specification
Supersedes data of May 17th 1999
File under BCcomponents, BC02

2002 Jan 22

Varistors

2322 592 to 2322 595

FEATURES

- Zinc oxide disc, epoxy coated
- Straight leads
- Straight leads with flange (2322 592 and 593 series only)
- Kinked leads.

APPLICATION

- Suppression of transients.

DESCRIPTION

The varistors consist of a disc of low- β ceramic material with two tinned solid copper leads. They are coated with a layer of ochre coloured epoxy, which provides electrical, mechanical and climatic protection. The encapsulation is resistant to all cleaning solvents in accordance with "IEC 60068-2-45".

MARKING

The varistors are marked with the following information:

- Maximum continuous RMS voltage
- Series number (592, 593, 594 or 595)
- Manufacturers logo
- Date of manufacture.

ORDERING INFORMATION

The varistors are available in a number of packaging options:

- Bulk
- On tape on reel
- On tape in ammopack.

The basic ordering code for each option is given in Tables 3, 4 and 5. To complete the catalogue number and to determine the required operating parameters, see Table 7.

MOUNTING

The varistors are suitable for processing on automatic insertion and cutting and bending equipment.

Varistors with flanged leads provide better positioning on printed-circuit boards (PCB) and more accurate control over component height. This is important for hand mounting and automatic insertion techniques; see Fig.4.

Soldering

≤ 240 °C; duration ≤ 5 s.

Resistance to heat

≤ 260 °C; duration ≤ 5 s.

INFLAMMABILITY

The varistors are non-flammable.

QUICK REFERENCE DATA

PARAMETER	VALUE	UNIT
Maximum continuous voltage:		
RMS	14 to 550	V
DC	18 to 745	V
Maximum non-repetitive transient current I_{nrp} ($8 \times 20 \mu s$)	100 to 4500	A
Robustness of terminations	10	N
Drop test:		
Height of fall	1	m
Detailed specification	based on CECC 42000	
Climatic category	40/085/56	

Varistors

2322 592 to 2322 595

MECHANICAL DATA

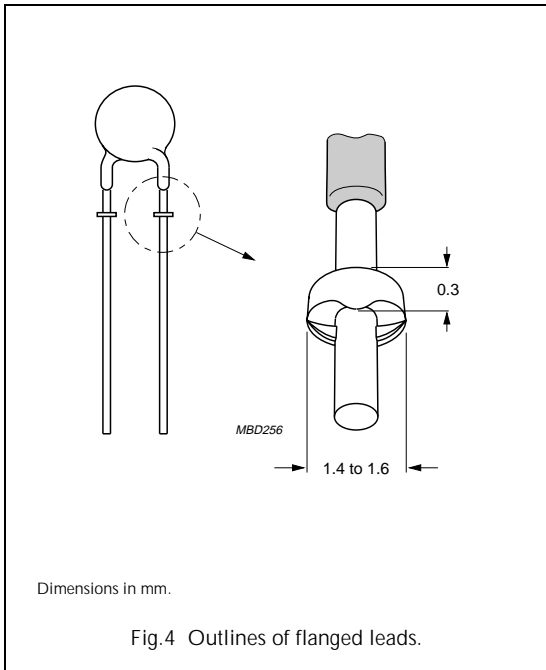
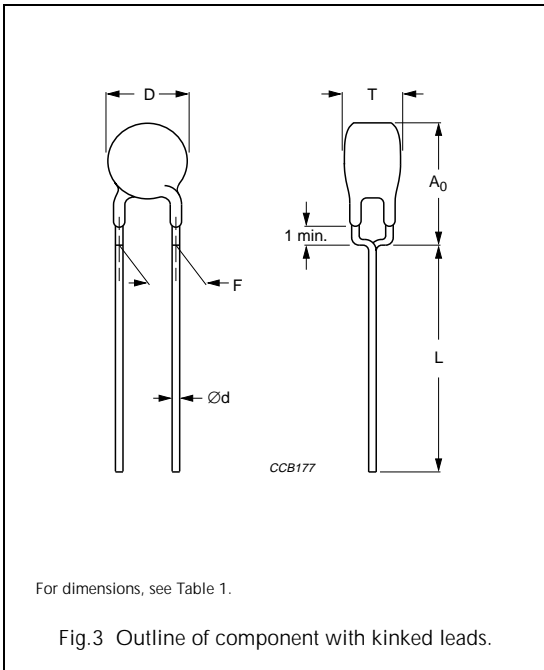
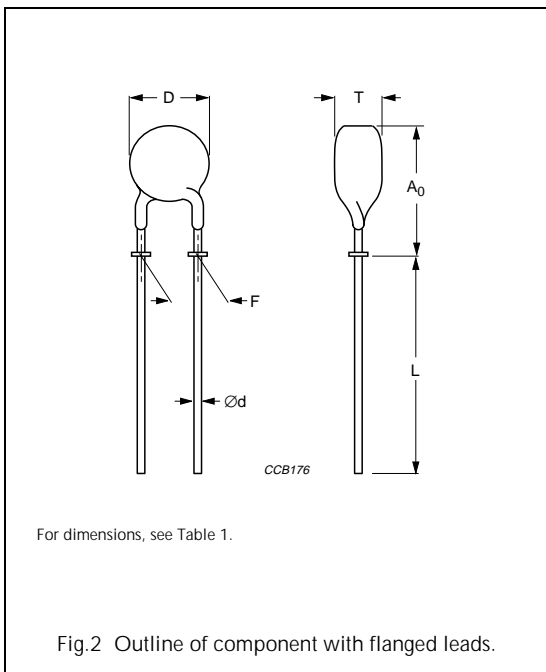
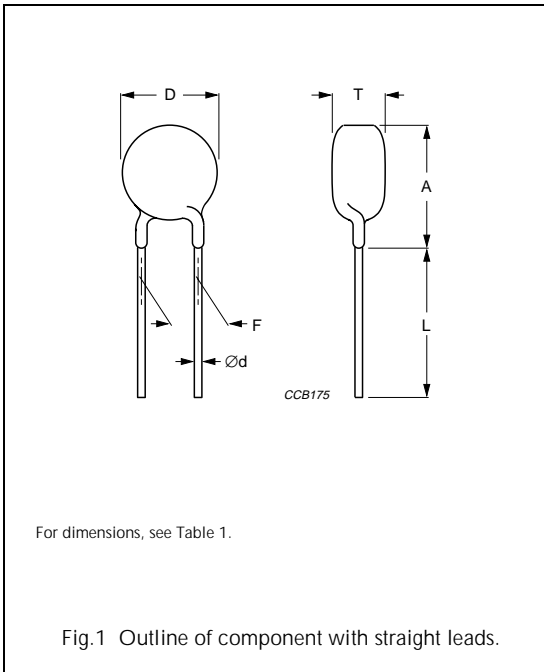

Varistors

2322 592 to 2322 595

Table 1 Component dimensions and catalogue numbers

D MAX. (mm)	A MAX. (mm)	A ₀ MAX. (mm)	L MIN. (mm)	T MAX. (mm)	T MIN. (mm)	∅d (mm)	F (mm)	CATALOGUE NUMBER
7.0	9.0	11.0	27.0	6	4.1	0.6 ±0.05	5 +0.6/-0.1	2322 592
9.0	11.0	13.0	27.0	6	4.1	0.6 ±0.05	5 +0.6/-0.1	2322 593
13.5	15.5	18.0	17.0	7	4.4	0.8 ±0.05	7.5 ±0.8	2322 594
17.0	19.0	23.0	16.0	7	4.4	0.8 ±0.05	7.5 ±0.8	2322 595

PACKAGING

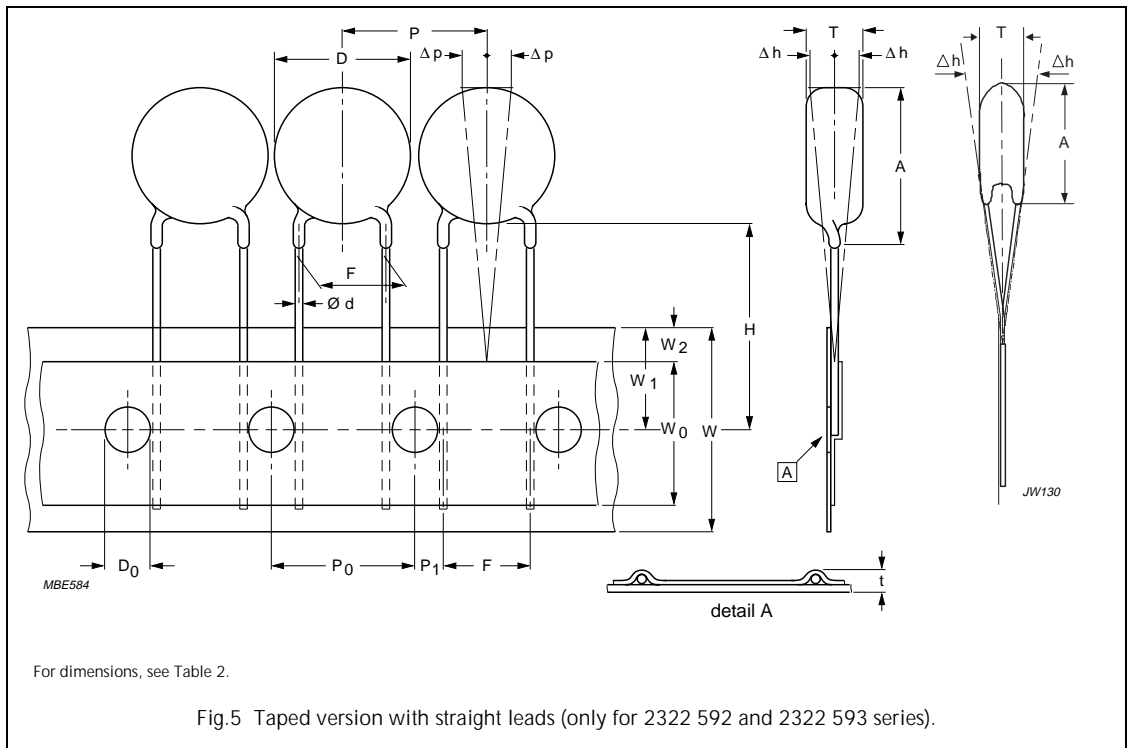

Varistors

2322 592 to 2322 595

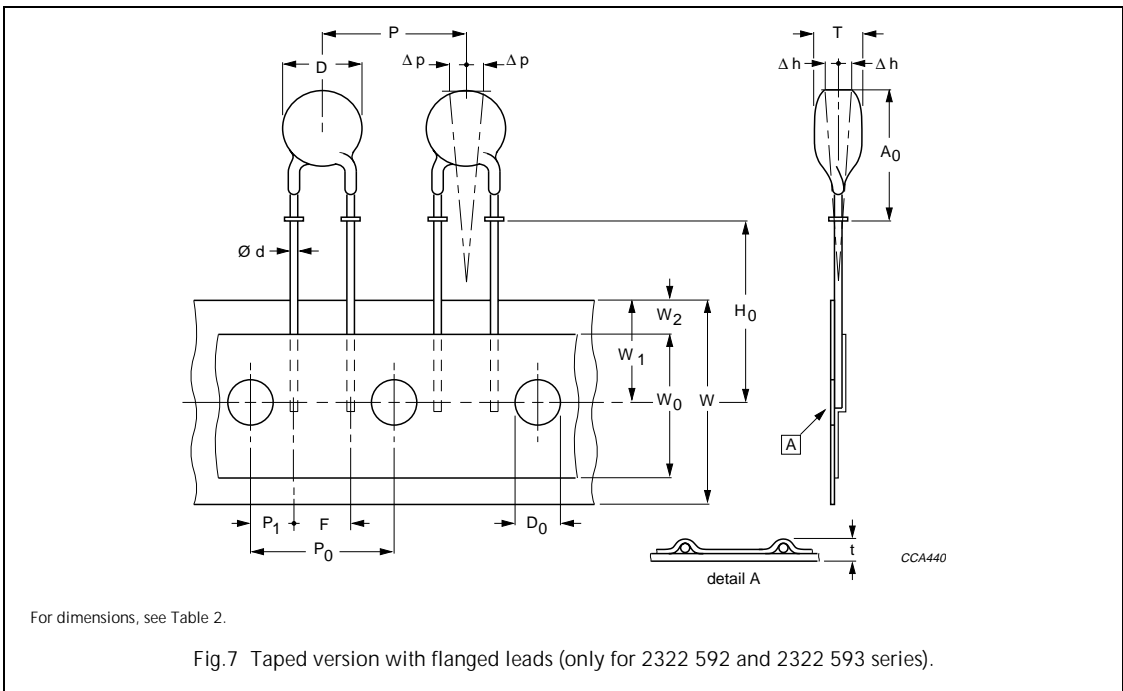
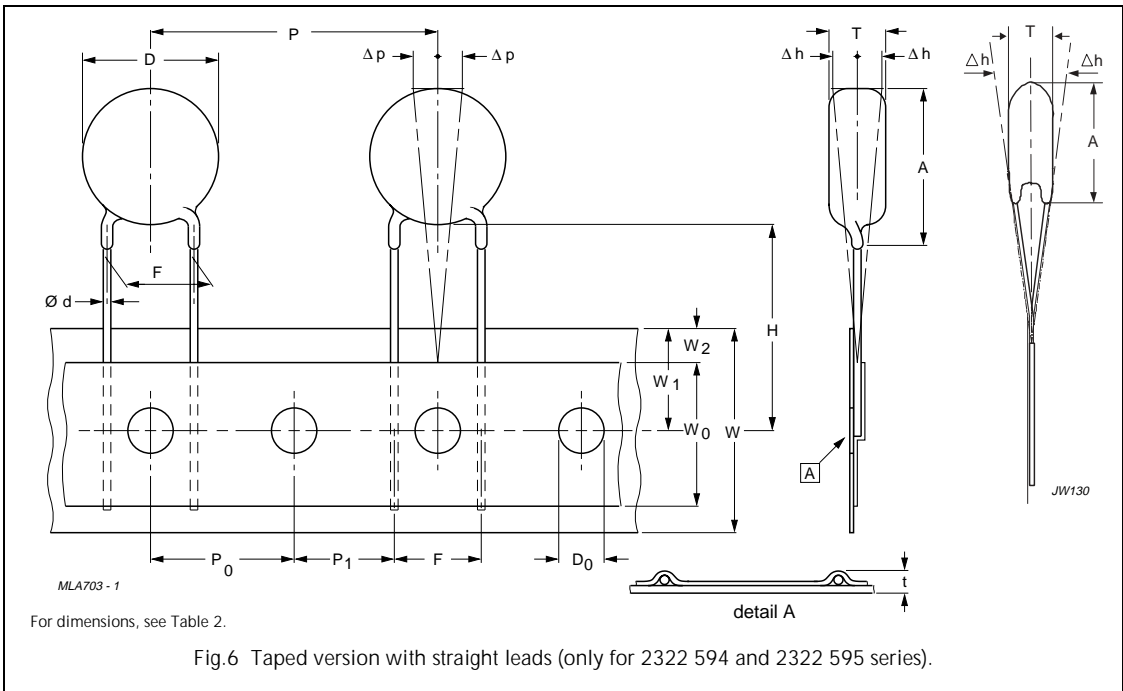

Varistors

2322 592 to 2322 595

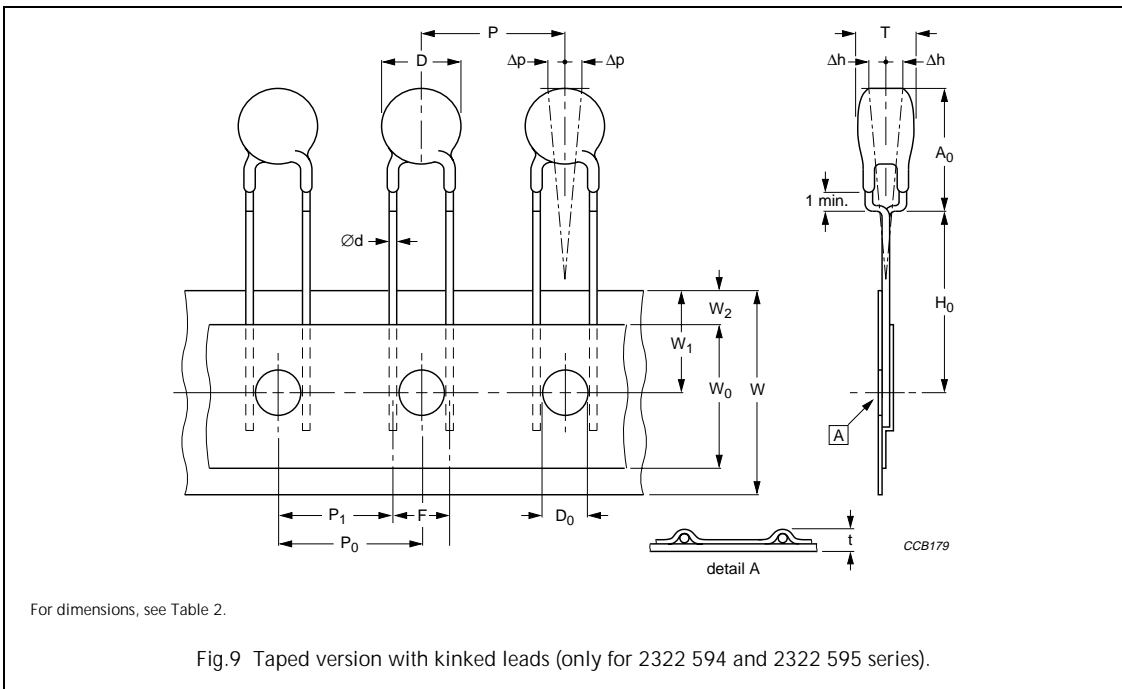
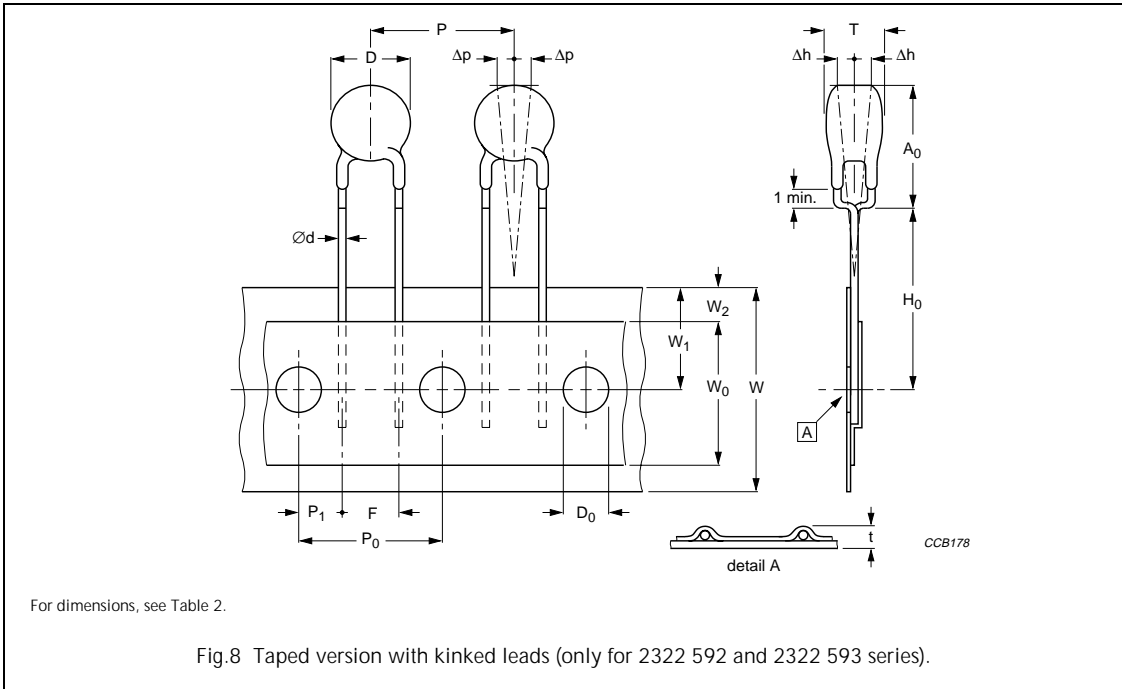

Varistors

2322 592 to 2322 595

Table 2 Taping data (based on "IEC 60286-2")

SYMBOL	PARAMETER	DIMENSIONS NOMINAL (mm)		TOLERANCE (mm)	REMARKS
D	body diameter	see Table 1			
T	total thickness	see Table 1			
A ₀ ; A	mounting height	see Table 1			
∅d	lead diameter	see Table 1			
F	lead to lead distance	see Table 1			guaranteed between component and tape
P	component pitch	12.7 or 25.4		±1.0	
P ₀	feed hole pitch	12.7		±0.3	cumulative pitch error ±1 mm/20 pitches
P ₁	feed hole centre to lead centre	3.85 or 8.95		±0.7	guaranteed between component and tape
Δp	component alignment	0.0		±1.3	
Δh	component alignment	0.0		±2.0	
W	tape width	18.0		+1.0/-0.5	
W ₀	hold down tape width	≥12.5			
W ₁	hole position	9.0		±0.5	
W ₂	hold down tape position	≤3.0			
H	height between component and tape centre	18.0		+2.0/-0.0	straight lead version 2322 594 and 2322 595
		20.0		+2.0/-0.0	straight lead version 2322 592 and 2322 593
H ₀	lead-wire flange height	16.0 or 18.25		±0.5	flanged and kinked lead versions
D ₀	feed hole diameter	4.0		±0.2	
t	total tape thickness	≤1.4			with cardboard tape 0.5 ±0.1 mm

Varistors

2322 592 to 2322 595

Table 3 Varistors on tape on reel

TYPE	2322 592 Ø7 mm 14 V to 460 V	2322 593 Ø9 mm 14 V to 460 V	2322 594 Ø13.5 mm 14 V to 550 V	2322 595 Ø17 mm 14 V to 460 V
Straight leads:				
H = 18 mm (2322 594 and 2322 595); see Fig.6	0...6	0...6	0...6	0...6
H = 20 mm (2322 592 and 2322 593); see Fig.5	0...6	0...6	0...6	0...6
Straight leads with flange; H ₀ = 16 mm; see Fig.7	1...6	1...6	–	–
Straight leads with flange; H ₀ = 18.25 mm; see Fig.7	2...6	2...6	–	–
Kinked leads; H ₀ = 18.25 mm; see Fig.9	3...6	3...6	3...6	3...6
Kinked leads; H ₀ = 16 mm; see Fig.8	8...6	8...6	8...6	8...6
Package quantities				
14 V to 385 V	3000	3000	1500	1500
≥420 V	–	–	–	1000
510 V to 550 V	–	–	1200	1200

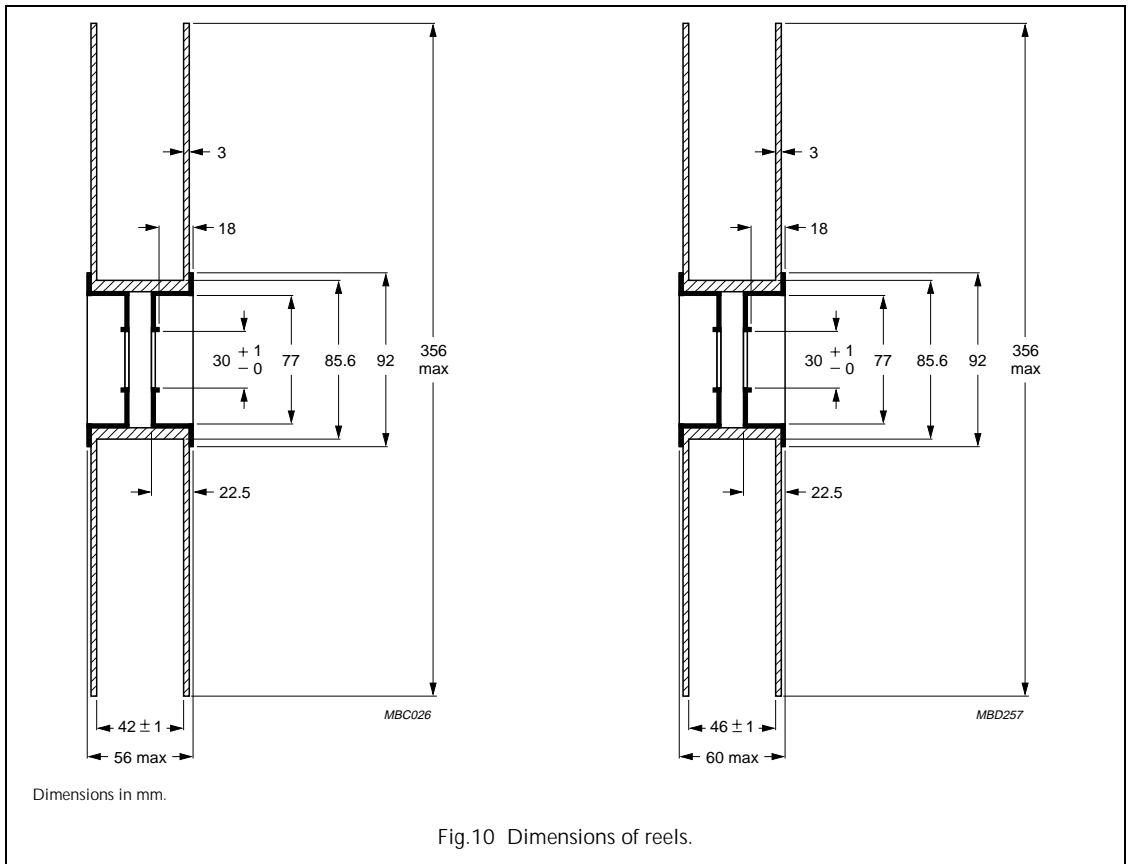

Varistors

2322 592 to 2322 595

Table 4 Varistors on tape in ammpack

TYPE	2322 592 Ø7 mm 14 V to 460 V	2322 593 Ø9 mm 14 V to 460 V	2322 594 Ø13.5 mm 14 V to 550 V	2322 595 Ø17 mm 14 V to 550 V
Straight leads; H = 18 or 20 mm; see Figs 5 and 6	0...7	0...7	0...7	0...7
Straight leads with flange; H ₀ = 16 mm; see Fig.7	1...7	1...7	–	–
Straight leads with flange; H ₀ = 18.25 mm; see Fig.7	2...7	2...7	–	–
Kinked leads; H ₀ = 18.25 mm; see Fig.9	3...7	3...7	3...7	3...7
Kinked leads; H ₀ = 16 mm; see Fig.8	8...7	8...7	8...7	8...7
Package quantities				
14 to 175 V	1500	1500	750	750
230 to 460 V	1000	1000	–	–
230 to 300 V	–	–	600	600
320 to 550 V	–	–	500	500

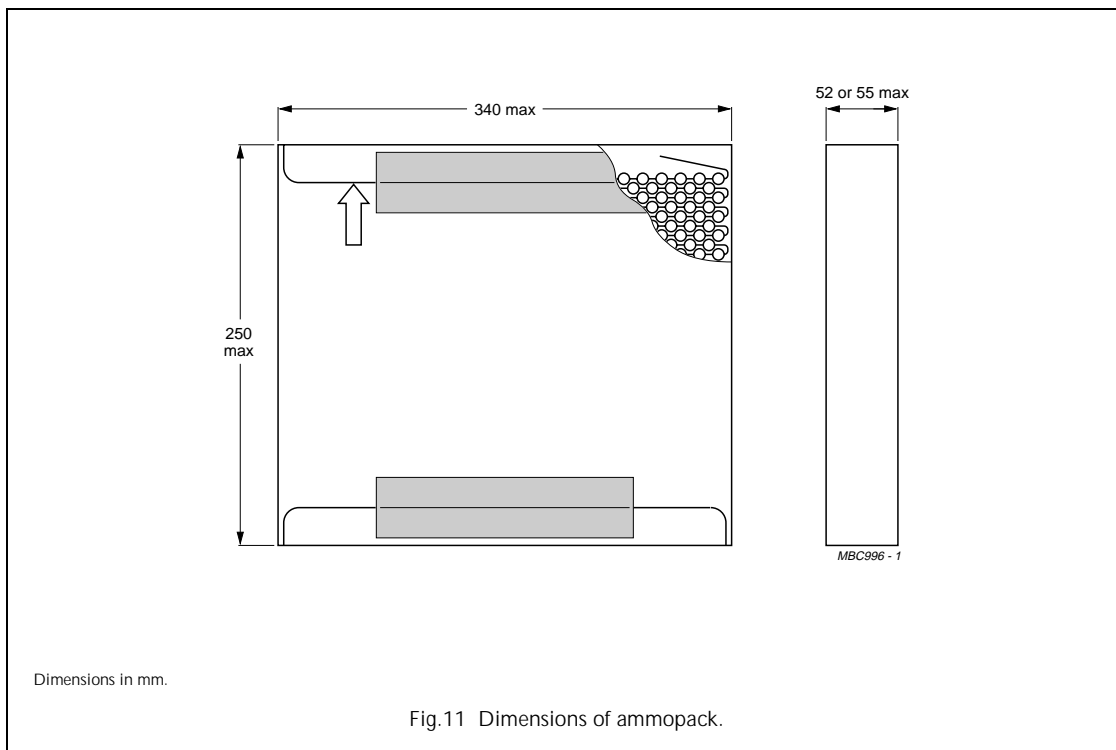

Varistors

2322 592 to 2322 595

Table 5 Varistors in bulk

TYPE	2322 592 Ø7 mm 14 V to 460 V	2322 593 Ø9 mm 14 V to 460 V	2322 594 Ø13.5 mm 14 V to 550 V	2322 595 Ø17 mm 14 V to 550 V
Straight leads; see Fig.1	5...6	5...6	5...6	5...6
Straight leads with flange; see Fig.2	7...6	7...6	–	–
Kinked leads; see Fig.3	6...6	6...6	6...6	6...6
Package quantities	250	250	250	100 and 250

Varistors

2322 592 to 2322 595

ELECTRICAL CHARACTERISTICS

Table 6 Electrical data

PARAMETER	VALUE	UNIT
Maximum continuous voltage:		
RMS	14 to 550	V
DC	18 to 745	V
Maximum non-repetitive transient current (I_{nrp}) ($8 \times 20 \mu s$):		
2322 592	100 or 400	A
2322 593	250 or 1200	A
2322 594	500 or 2500	A
2322 595	1000 or 4500	A
Thermal resistance:		
2322 592	≈ 80	K/W
2322 593	≈ 70	K/W
2322 594	≈ 60	K/W
2322 595	≈ 50	K/W
Maximum dissipation:		
2322 592	100	mW
2322 593	250	mW
2322 594	400	mW
2322 595	600	mW
Temperature coefficient of voltage at 1 mA maximum	-0.065	%/K
Voltage proof between interconnected leads and case	2500	V
Climatic category	40/085/56	

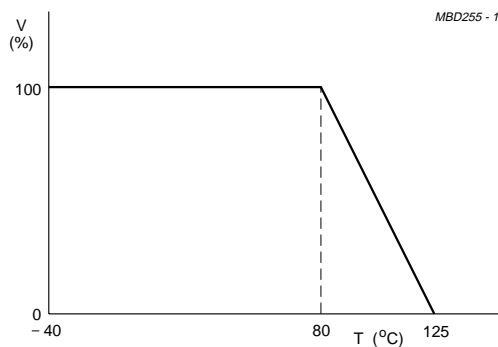

Fig.12 Derating curve.

Varistors

2322 592 to 2322 595

Table 7 Electrical data and ordering information

Replace last digit of catalogue number with a '7' for ordering on tape in ammpack.

MAXIMUM CONTINUOUS VOLTAGE		VOLTAGE ⁽²⁾ at 1 mA	MAXIMUM VOLTAGE at STATED CURRENT		MAXIMUM ENERGY ⁽³⁾ (10 × 1000 µs)	MAXIMUM NON-REP. TRANSIENT CURRENT ⁽⁴⁾ I _{nrp} (8 × 20 µs)	TYPICAL CAPACITANCE at 1 kHz	CATALOGUE NUMBERS
RMS ⁽¹⁾ (V)	DC (V)		V (V)	I (A)				
14	18	22	48	1.0	0.5	100	1300	592 .1406 ⁽⁵⁾
			43	2.5	1.7	250	2800	593 .1406 ⁽⁵⁾
			43	5.0	4.3	500	6000	594 .1406 ⁽⁵⁾
			43	10.0	5.4	1000	15000	595 .1406 ⁽⁵⁾
17	22	27	60	1.0	0.7	100	1050	592 .1706 ⁽⁵⁾
			53	2.5	2.0	250	2000	593 .1706 ⁽⁵⁾
			53	5.0	5.3	500	4000	594 .1706 ⁽⁵⁾
			53	10.0	6.9	1000	10000	595 .1706 ⁽⁵⁾
20	26	33	73	1.0	0.8	100	900	592 .2006 ⁽⁵⁾
			65	2.5	2.5	250	1500	593 .2006 ⁽⁵⁾
			65	5.0	6.5	500	3000	594 .2006 ⁽⁵⁾
			65	10.0	8.8	1000	7500	595 .2006 ⁽⁵⁾
25	31	39	86	1.0	0.9	100	500	592 .2506 ⁽⁵⁾
			77	2.5	3.0	250	1350	593 .2506 ⁽⁵⁾
			77	5.0	7.7	500	2600	594 .2506 ⁽⁵⁾
			77	10.0	9.4	1000	6500	595 .2506 ⁽⁵⁾
30	38	47	96	1.0	1.1	100	700	592 .3006 ⁽⁶⁾
			93	2.5	3.6	250	1600	593 .3006 ⁽⁶⁾
			93	5.0	9.2	500	2700	594 .3006 ⁽⁶⁾
			90	10.0	12.0	1000	6000	595 .3006 ⁽⁶⁾
35	45	56	123	1.0	1.4	100	560	592 .3506 ⁽⁶⁾
			115	2.5	4.4	250	1300	593 .3506 ⁽⁶⁾
			110	5.0	11.0	500	2200	594 .3506 ⁽⁶⁾
			105	10.0	14.0	1000	4800	595 .3506 ⁽⁶⁾
40	56	68	145	1.0	1.6	100	460	592 .4006 ⁽⁶⁾
			135	2.5	5.2	250	1000	593 .4006 ⁽⁶⁾
			130	5.0	13.0	500	1800	594 .4006 ⁽⁶⁾
			130	10.0	17.0	1000	3800	595 .4006 ⁽⁶⁾
50	65	82	145	5.0	2.6	400	370	592 .5006 ⁽⁶⁾
			140	10.0	7.0	1200	900	593 .5006 ⁽⁶⁾
			140	25.0	12.0	2500	1500	594 .5006 ⁽⁶⁾
			140	50.0	21.0	4500	3100	595 .5006 ⁽⁶⁾

Varistors

2322 592 to 2322 595

MAXIMUM CONTINUOUS VOLTAGE		VOLTAGE ⁽²⁾ at 1 mA	MAXIMUM VOLTAGE at STATED CURRENT		MAXIMUM ENERGY ⁽³⁾ (10 × 1000 µs)	MAXIMUM NON-REP. TRANSIENT CURRENT ⁽⁴⁾ I _{nrrp} (8 × 20 µs)	TYPICAL CAPACITANCE at 1 kHz	CATALOGUE NUMBERS
RMS ⁽¹⁾ (V)	DC (V)		V (V)	I (A)				
60	85	100	165	5.0	2.9	400	290	592 .6006 ⁽⁶⁾
			165	10.0	8.3	1200	700	593 .6006 ⁽⁶⁾
			165	25.0	15.0	2500	1200	594 .6006 ⁽⁶⁾
			165	50.0	24.0	4500	2300	595 .6006 ⁽⁶⁾
75	100	120	190	5.0	3.4	400	240	592 .7506 ⁽⁶⁾
			200	10.0	10.0	1200	530	593 .7506 ⁽⁶⁾
			200	25.0	18.0	2500	1000	594 .7506 ⁽⁶⁾
			200	50.0	29.0	4500	1900	595 .7506 ⁽⁶⁾
95	125	150	230	5.0	4.1	400	180	592 .9506 ⁽⁶⁾
			250	10.0	13.0	1200	450	593 .9506 ⁽⁶⁾
			250	25.0	22.0	2500	800	594 .9506 ⁽⁶⁾
			250	50.0	37.0	4500	1500	595 .9506 ⁽⁶⁾
130	170	205	310	5.0	5.5	400	130	592 .1316 ⁽⁶⁾
			340	10.0	17.0	1200	320	593 .1316 ⁽⁶⁾
			340	25.0	30.0	2500	580	594 .1316 ⁽⁶⁾
			340	50.0	56.0	4500	1050	595 .1316 ⁽⁶⁾
140	180	220	350	5.0	6.3	400	120	592 .1416 ⁽⁶⁾
			370	10.0	21.0	1200	290	593 .1416 ⁽⁶⁾
			370	25.0	33.0	2500	540	594 .1416 ⁽⁶⁾
			370	50.0	57.0	4500	950	595 .1416 ⁽⁶⁾
150	200	240	395	5.0	7.1	400	110	592 .1516 ⁽⁶⁾
			400	10.0	20.0	1200	270	593 .1516 ⁽⁶⁾
			400	25.0	36.0	2500	490	594 .1516 ⁽⁶⁾
			400	50.0	59.0	4500	850	595 .1516 ⁽⁶⁾
175	225	275	410	5.0	7.3	400	90	592 .1716 ⁽⁶⁾
			455	10.0	23.0	1200	230	593 .1716 ⁽⁶⁾
			455	25.0	41.0	2500	430	594 .1716 ⁽⁶⁾
			455	50.0	67.0	4500	750	595 .1716 ⁽⁶⁾
230	300	360	560	5.0	10.0	400	70	592 .2316 ⁽⁶⁾
			600	10.0	30.0	1200	170	593 .2316 ⁽⁶⁾
			600	25.0	54.0	2500	320	594 .2316 ⁽⁶⁾
			600	50.0	88.0	4500	540	595 .2316 ⁽⁶⁾

Varistors

2322 592 to 2322 595

MAXIMUM CONTINUOUS VOLTAGE		VOLTAGE ⁽²⁾ at 1 mA	MAXIMUM VOLTAGE at STATED CURRENT		MAXIMUM ENERGY ⁽³⁾ (10 × 1000 µs)	MAXIMUM NON-REP. TRANSIENT CURRENT ⁽⁴⁾ I _{nrrp} (8 × 20 µs)	TYPICAL CAPACITANCE at 1 kHz	CATALOGUE NUMBERS
RMS ⁽¹⁾ (V)	DC (V)		V (V)	I (A)				
250	320	390	600	5.0	11.0	400	60	592 .2516 ⁽⁶⁾
			650	10.0	33.0	1200	160	593 .2516 ⁽⁶⁾
			650	25.0	58.0	2500	300	594 .2516 ⁽⁶⁾
			650	50.0	96.0	4500	480	595 .2516 ⁽⁶⁾
275	350	430	695	5.0	12.0	400	55	592 .2716 ⁽⁶⁾
			710	10.0	36.0	1200	140	593 .2716 ⁽⁶⁾
			710	25.0	63.0	2500	270	594 .2716 ⁽⁶⁾
			710	50.0	104.0	4500	440	595 .2716 ⁽⁶⁾
300	385	470	750	5.0	13.0	400	50	592 .3016 ⁽⁶⁾
			800	10.0	40.0	1200	130	593 .3016 ⁽⁶⁾
			800	25.0	71.0	2500	240	594 .3016 ⁽⁶⁾
			800	50.0	117.0	4500	400	595 .3016 ⁽⁶⁾
320	420	510	800	5.0	15.0	400	45	592 .3216 ⁽⁶⁾
			850	10.0	44.0	1200	120	593 .3216 ⁽⁶⁾
			850	25.0	77.0	2500	220	594 .3216 ⁽⁶⁾
			850	50.0	120.0	4500	370	595 .3216 ⁽⁶⁾
385	505	620	1000	5.0	18.0	400	40	592 .3816 ⁽⁶⁾
			1025	10.0	51.0	1200	95	593 .3816 ⁽⁶⁾
			1025	25.0	67.0	2500	180	594 .3816 ⁽⁶⁾
			1025	50.0	110.0	4500	280	595 .3816 ⁽⁶⁾
420	560	680	1100	5.0	20.0	400	35	592 .4216 ⁽⁶⁾
			1120	10.0	56.0	1200	85	593 .4216 ⁽⁶⁾
			1120	25.0	73.0	2500	165	594 .4216 ⁽⁶⁾
			1120	50.0	120.0	4500	250	595 .4216 ⁽⁶⁾
460	615	750	1200	5.0	21.0	400	30	592 .4616 ⁽⁶⁾
			1240	10.0	63.0	1200	75	593 .4616 ⁽⁶⁾
			1240	25.0	82.0	2500	150	594 .4616 ⁽⁶⁾
			1240	50.0	135.0	4500	225	595 .4616 ⁽⁶⁾
510	670	820	1355	25.0	89.0	2500	135	594 .5116 ⁽⁶⁾
			1355	50.0	145.0	4500	220	595 .5116 ⁽⁶⁾
550	745	910	1500	25.0	98.0	2500	120	594 .5516 ⁽⁶⁾
			1500	50.0	160.0	4500	180	595 .5516 ⁽⁶⁾

Varistors

2322 592 to 2322 595

Notes to Table 7

1. The sinusoidal voltage is assumed as the normal operating condition. If a non-sinusoidal voltage is present, type selection should be based on multiplying the peak voltage by a factor of 0.707.
2. The voltage measured at 1 mA meets the requirements of "paragraph 4.3 of CECC specification 42000". The tolerance on the voltage at 1 mA is $\pm 10\%$.
3. High energy surges are generally of longer duration. The maximum energy for one pulse of $10 \times 1000 \mu\text{s}$ is given as a reference for longer duration pulses. This pulse can be characterised by peak current (I_p) and pulse width t_2 (virtual time of half I_p value, following "IEC 60060-2, section 6"). If V_p is the clamping voltage corresponding to I_p , the energy absorbed in the varistor is determined by the formula:

$$E = K \times V_p \times I_p \times t_2$$

where:

- a) K is dependent on the value of t_2 when the value of t_1 is between $8 \mu\text{s}$ and $10 \mu\text{s}$; see Fig.13.
4. A current wave of $8 \times 20 \mu\text{s}$ (requirement of "paragraph B.2.10.1 of CECC specification 42000") is used as a standard for pulse current and clamping voltage ratings. The maximum non-repetitive transient current is given for one pulse applied during the life of the component.
 5. Only available on request
 6. CECC approved types.

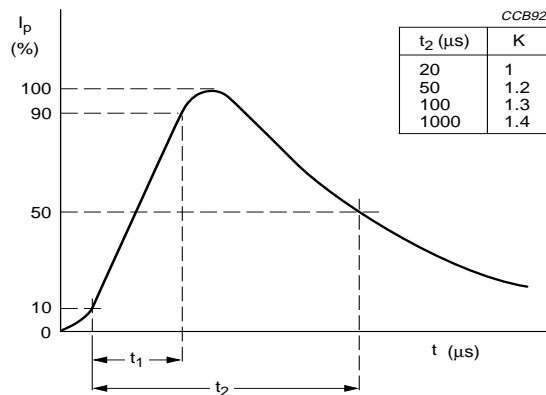

Fig.13 Peak current as a function of pulse width.

Varistors

2322 592 to 2322 595

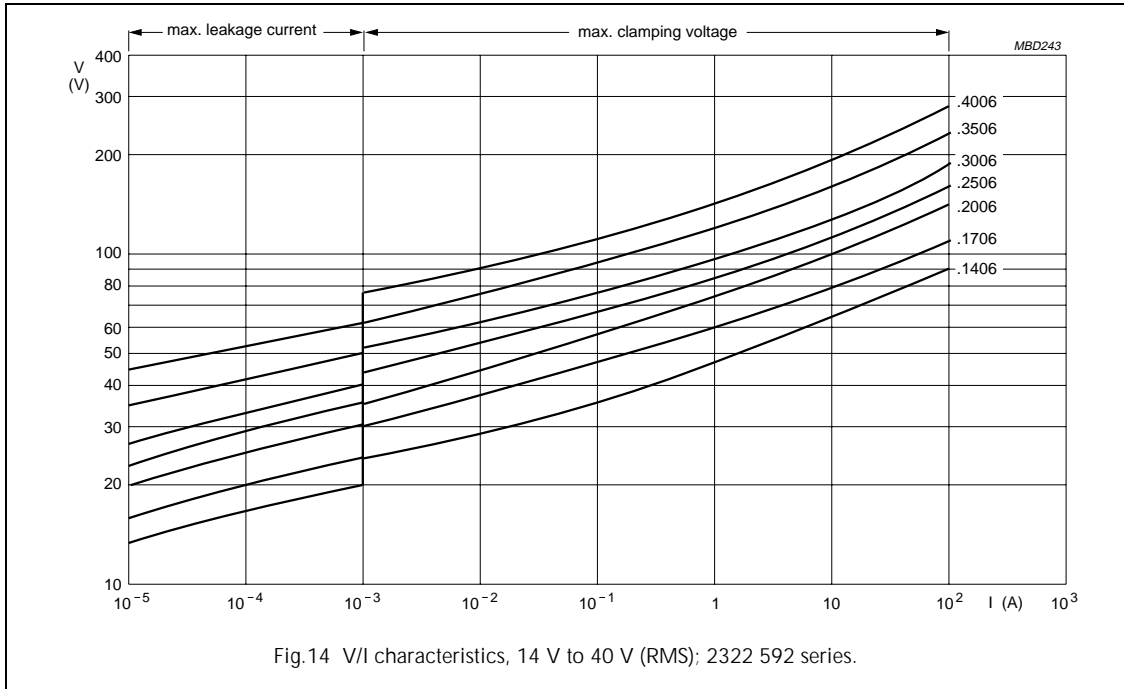

Fig.14 V/I characteristics, 14 V to 40 V (RMS); 2322 592 series.

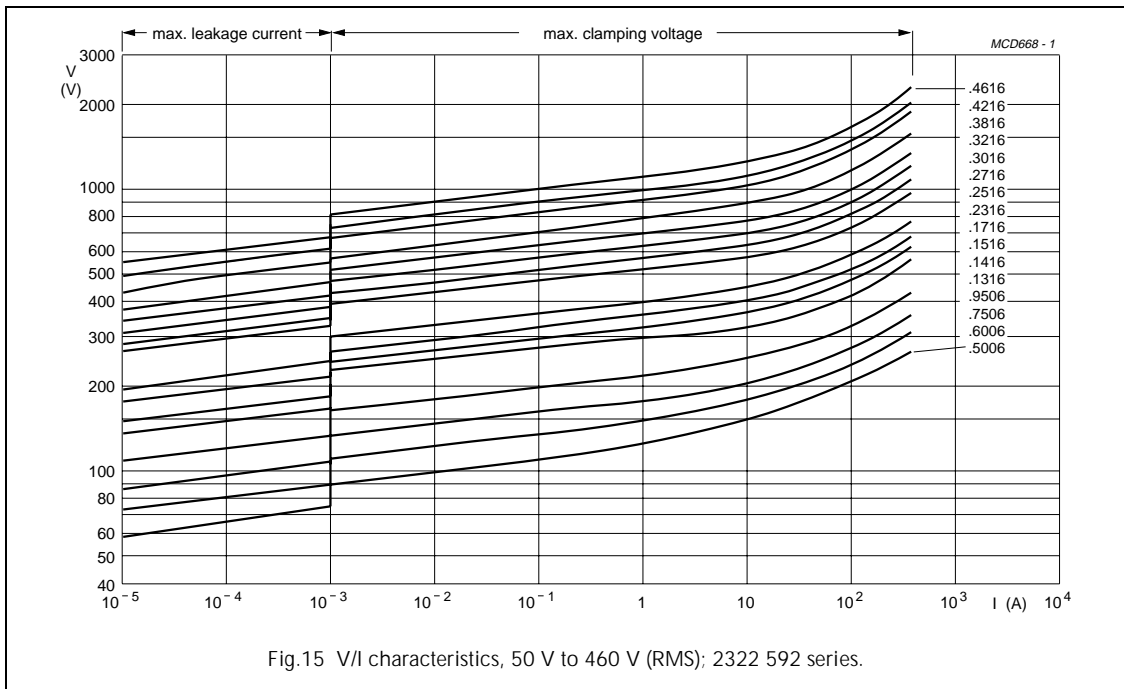

Fig.15 V/I characteristics, 50 V to 460 V (RMS); 2322 592 series.

Varistors

2322 592 to 2322 595

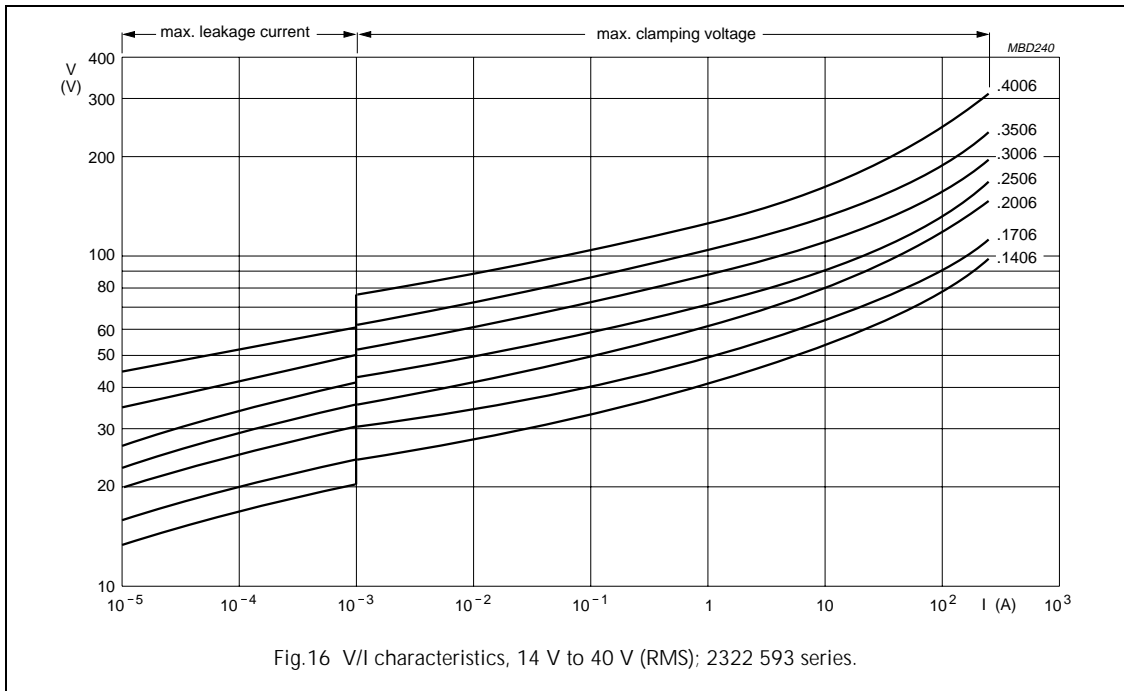

Fig.16 V/I characteristics, 14 V to 40 V (RMS); 2322 593 series.

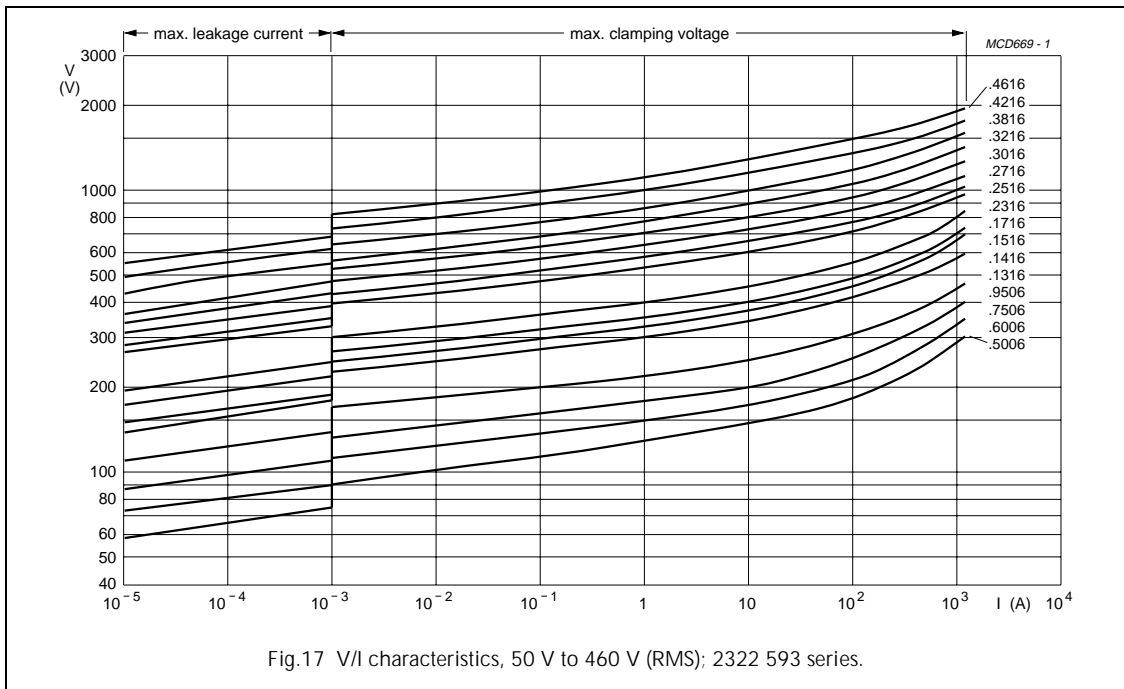
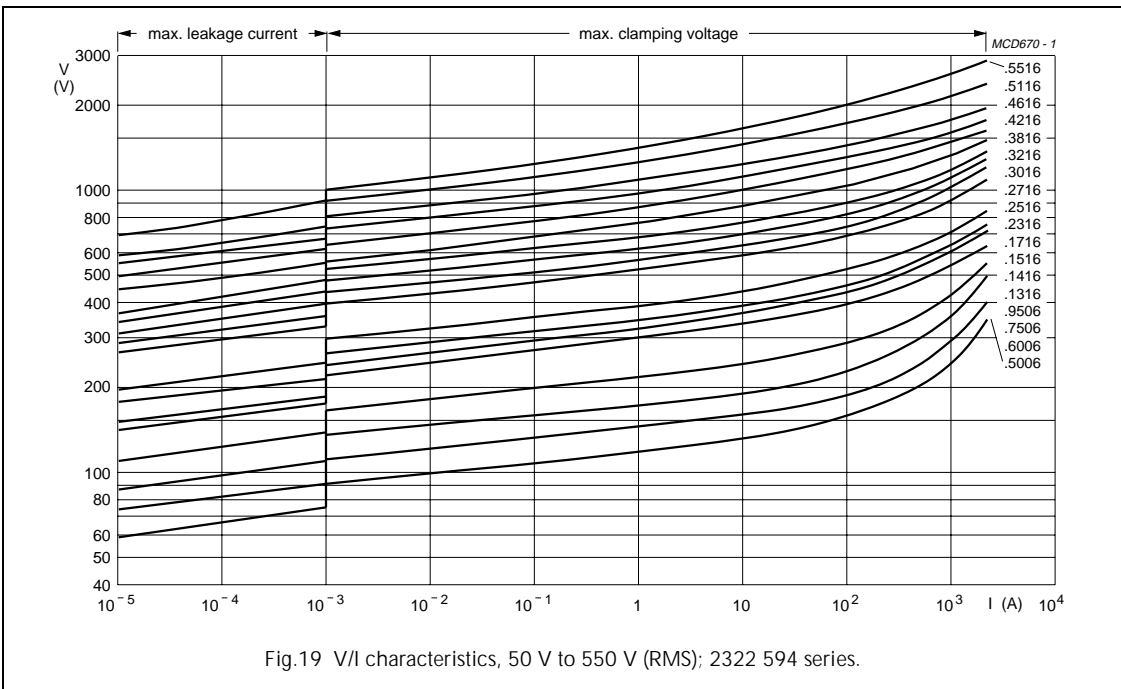
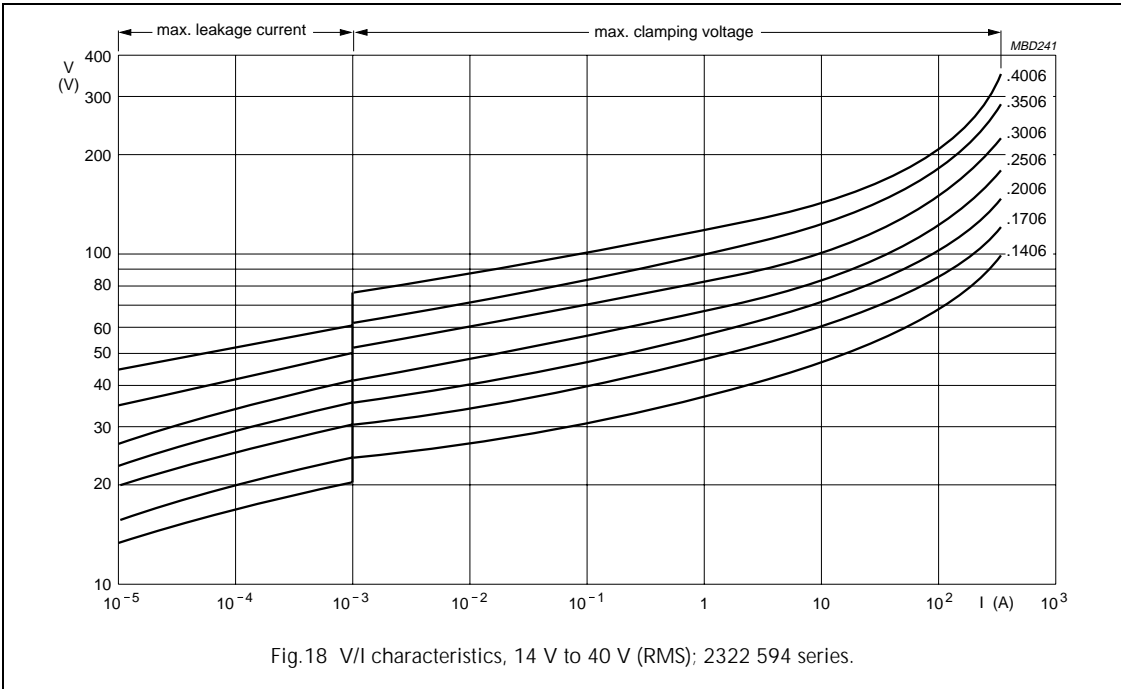

Fig.17 V/I characteristics, 50 V to 460 V (RMS); 2322 593 series.

Varistors

2322 592 to 2322 595



Varistors

2322 592 to 2322 595

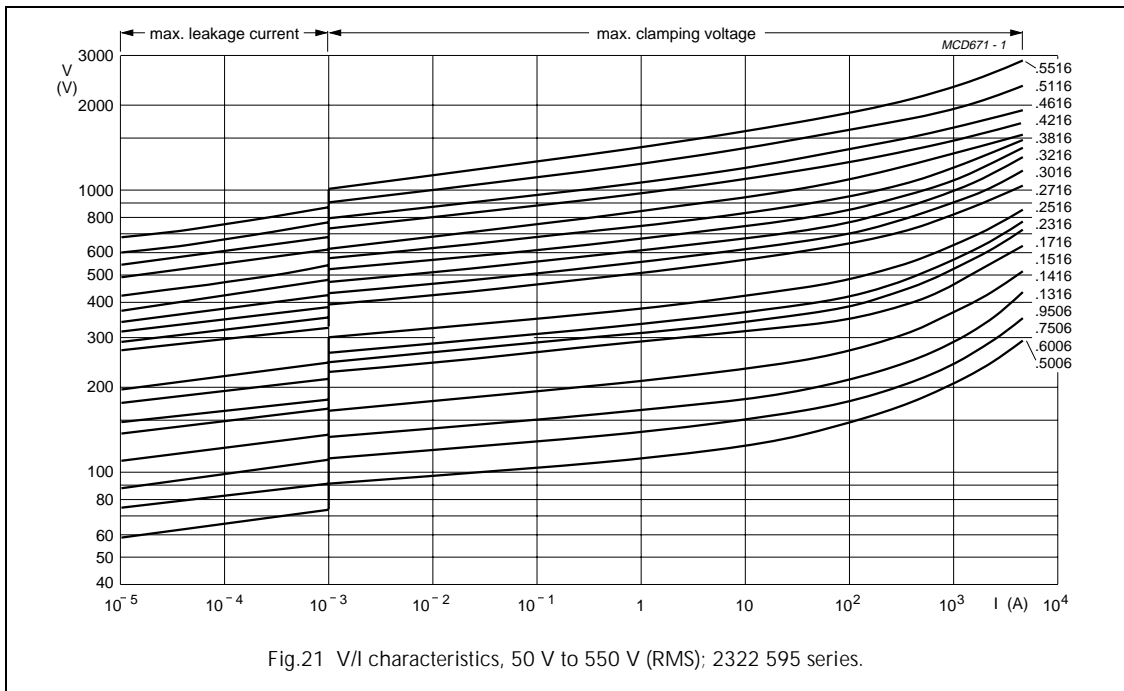
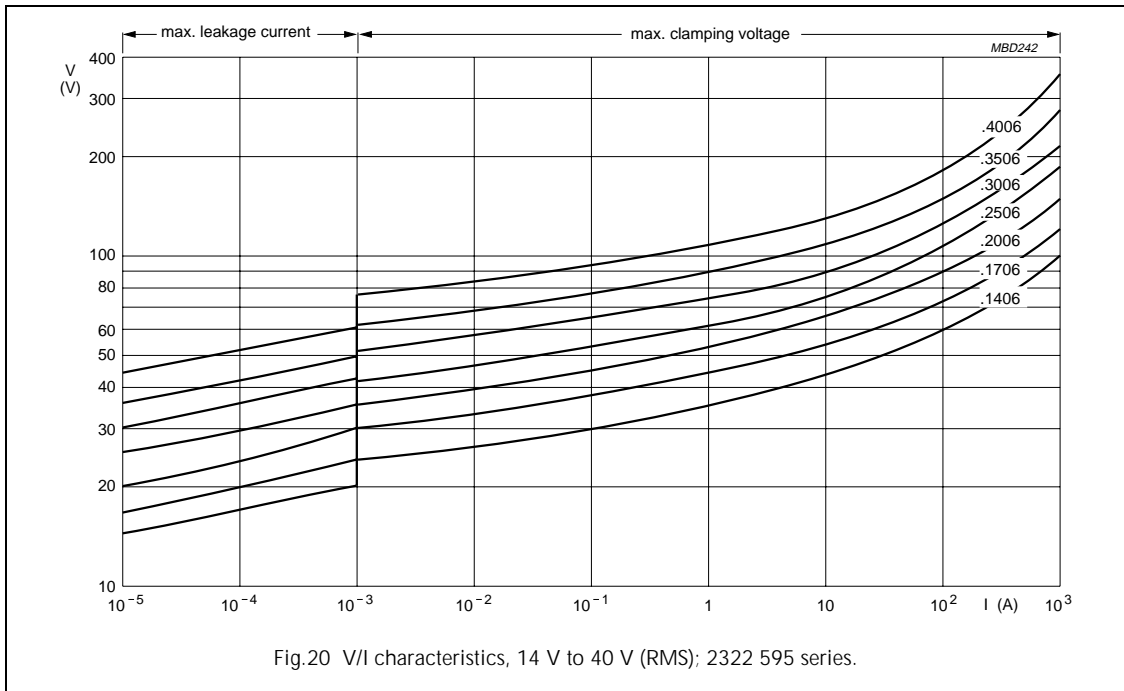

Varistors

2322 592 to 2322 595

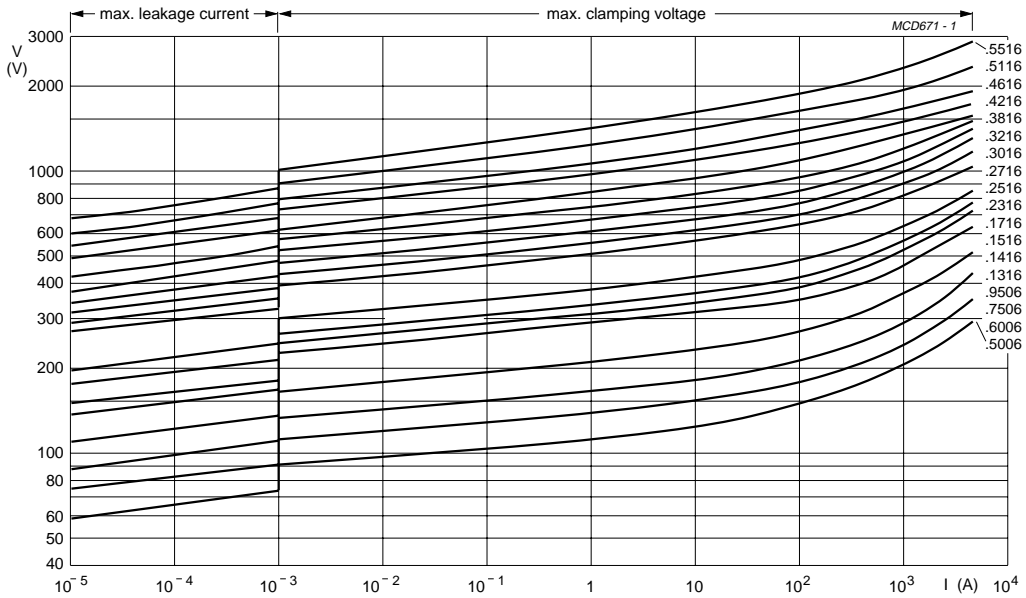

Fig.22 Maximum applicable transient current as a function of pulse duration, 14 V to 40 V (RMS); 2322 592 series.

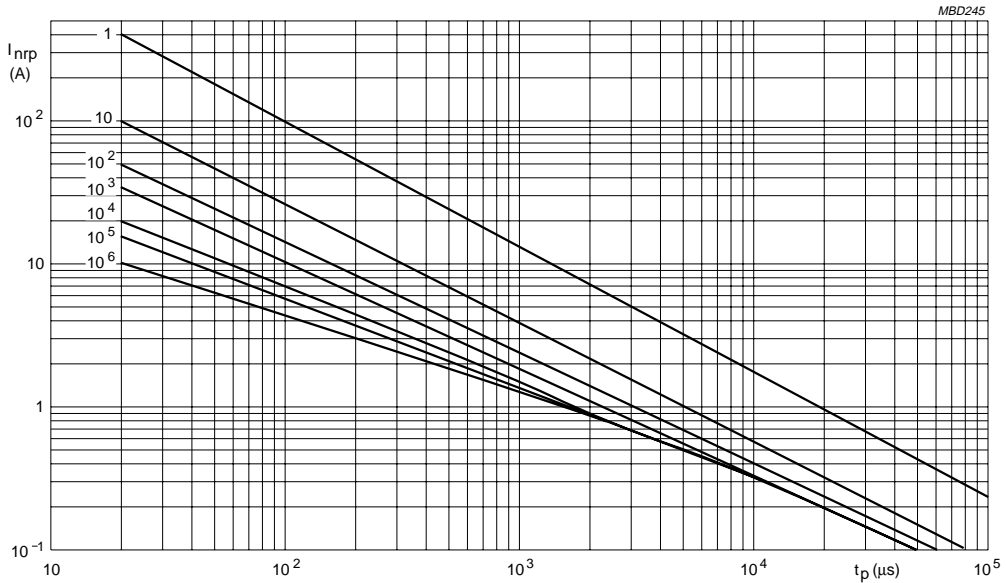
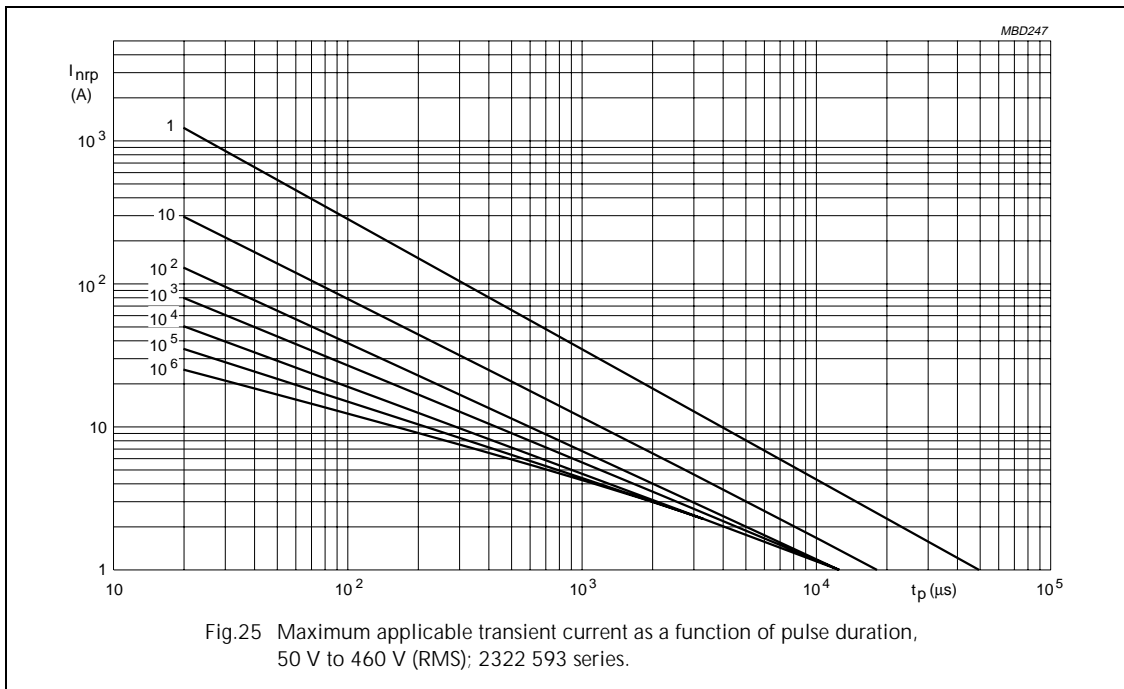
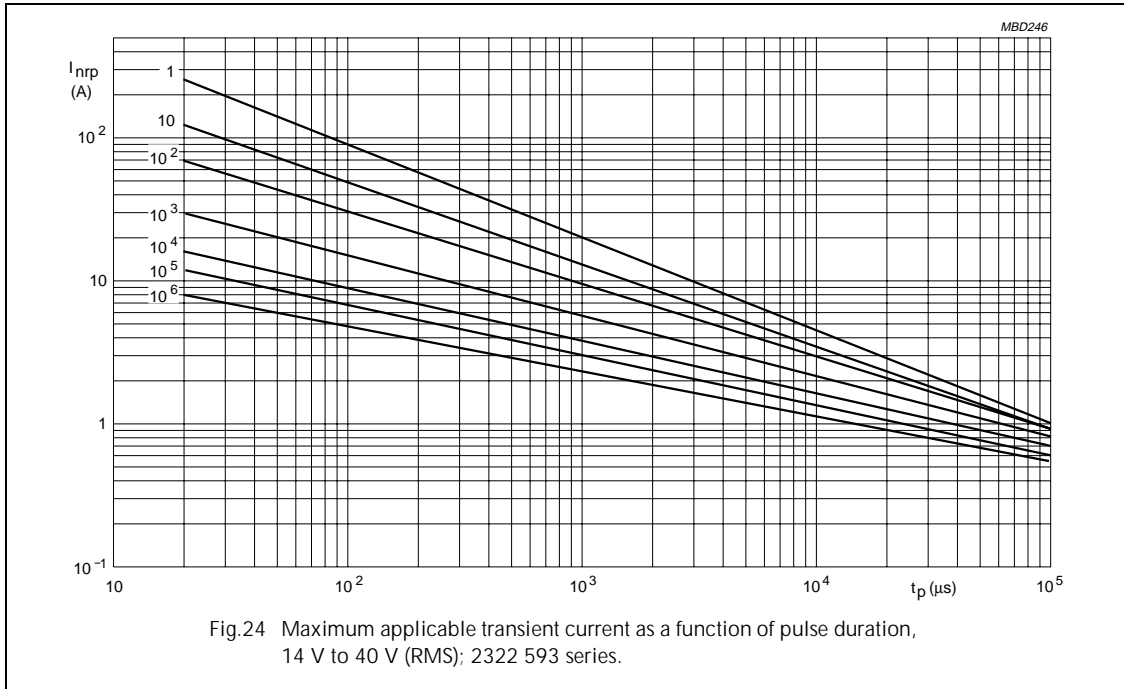

Fig.23 Maximum applicable transient current as a function of pulse duration, 50 V to 460 V (RMS); 2322 592 series.

Varistors

2322 592 to 2322 595



Varistors

2322 592 to 2322 595

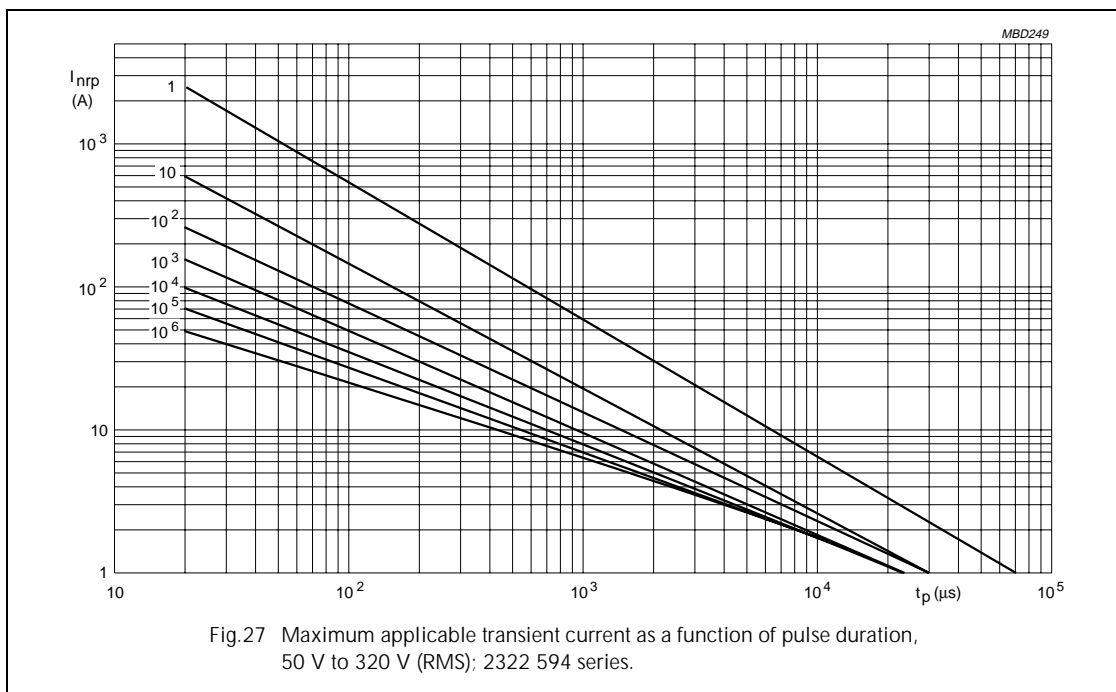
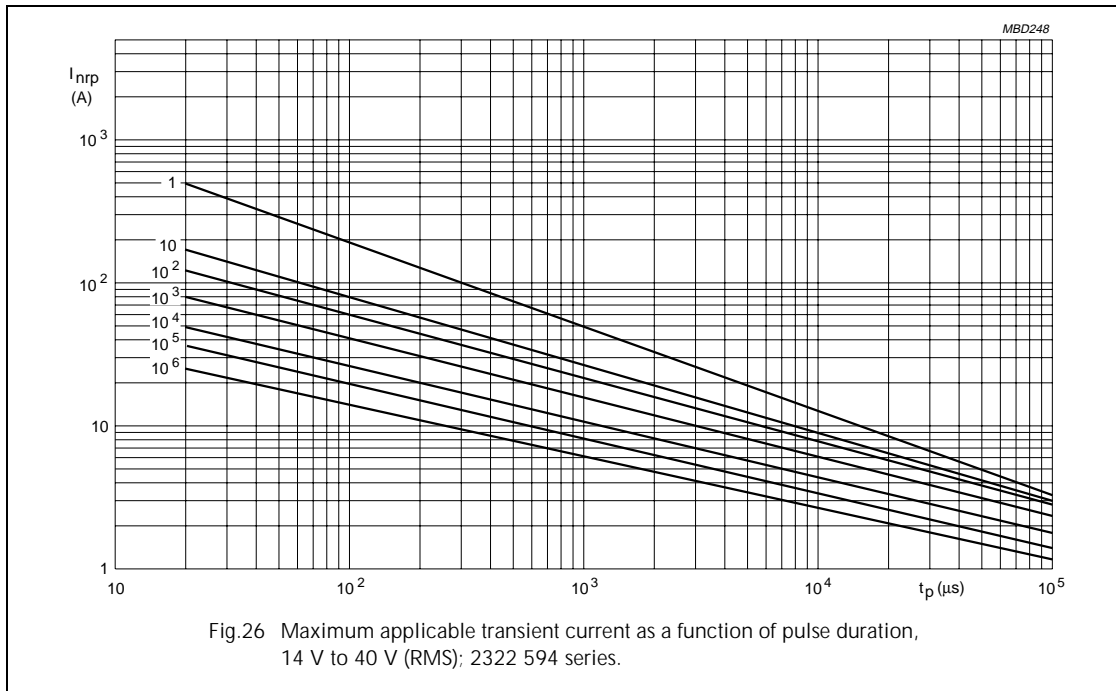

Varistors

2322 592 to 2322 595

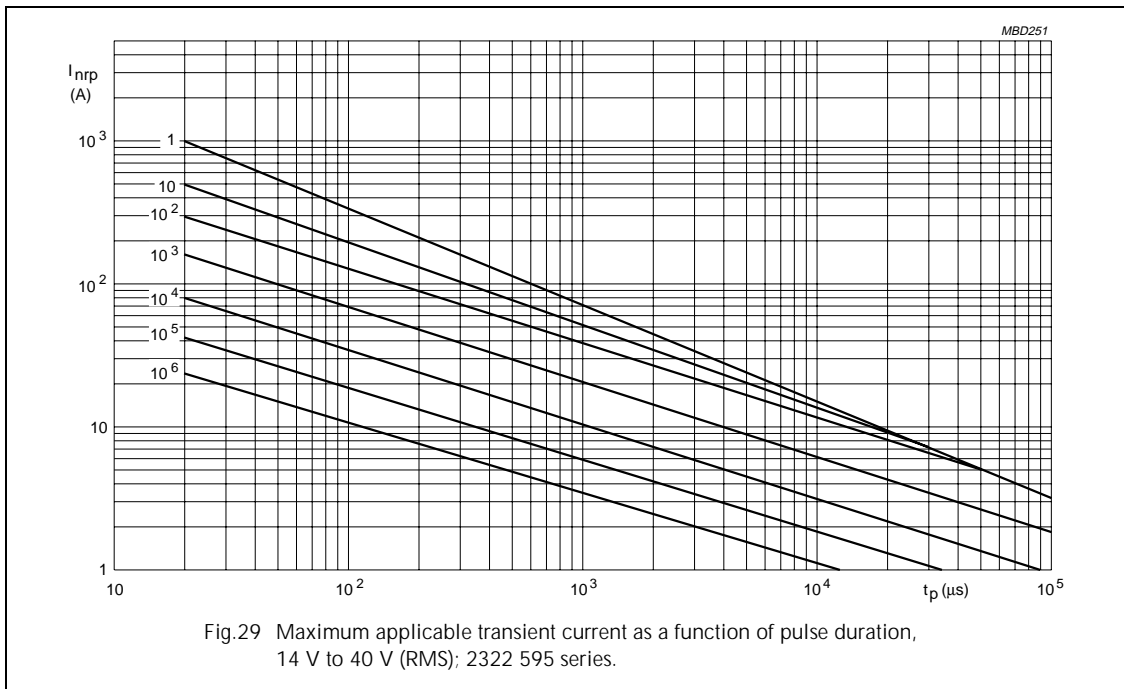
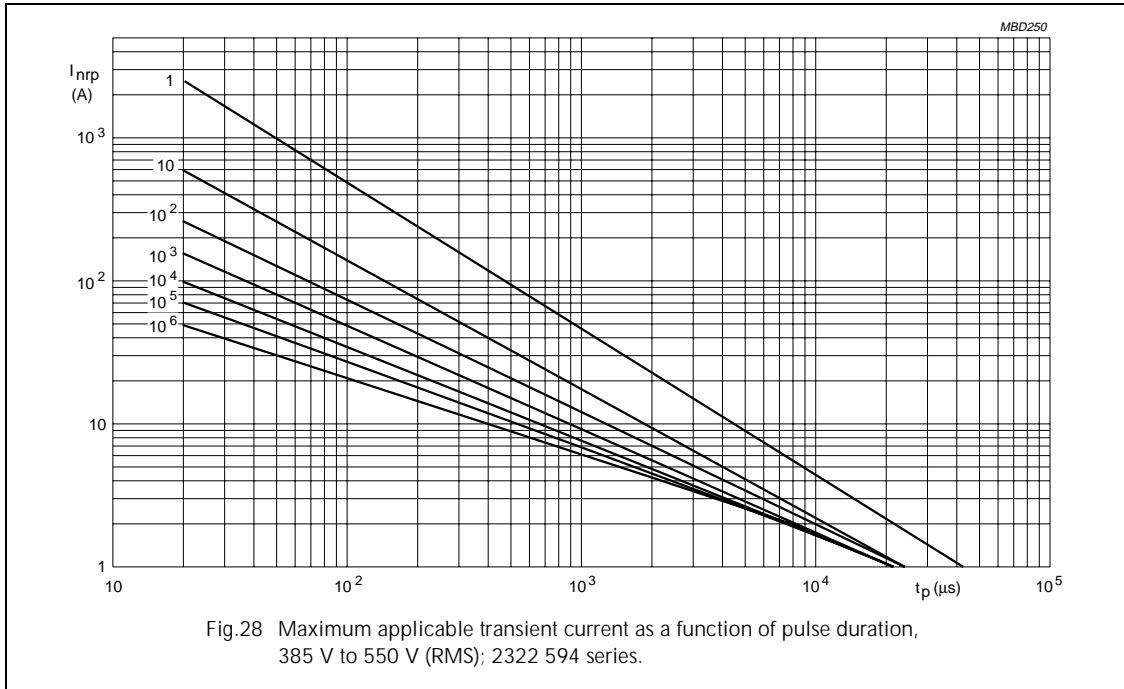

Varistors

2322 592 to 2322 595

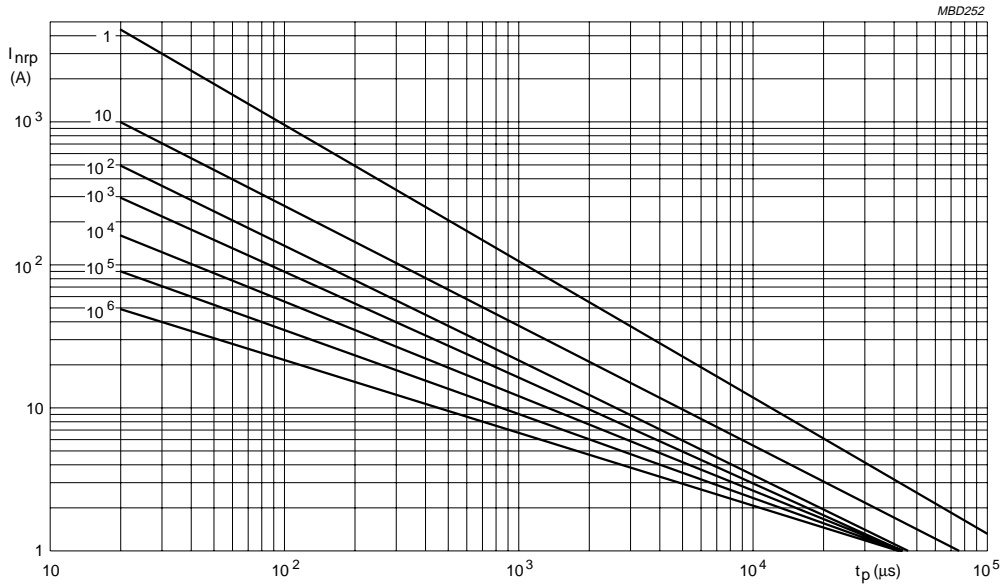

Fig.30 Maximum applicable transient current as a function of pulse duration, 50 V to 320 V (RMS); 2322 595 series.

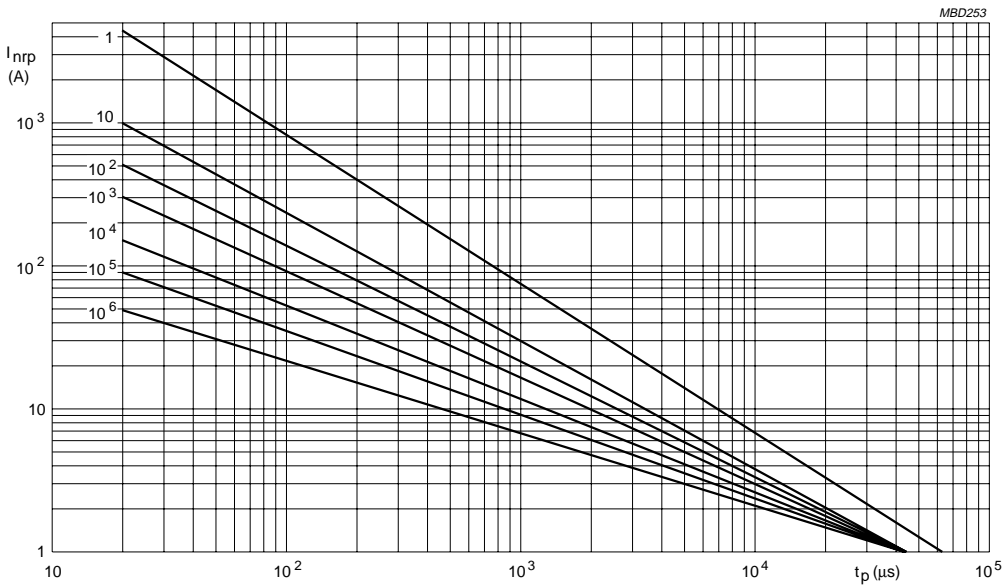

Fig.31 Maximum applicable transient current as a function of pulse duration, 385 V to 550 V (RMS); 2322 595 series.